

D-SERIES CRAWLER EXCAVATORS
CX250D | CX300D

CASE
CONSTRUCTION



IT'S TIME
FOR MORE

www.casece.com
EXPERTS FOR THE REAL WORLD
SINCE 1842

HERITAGE

A TRADITION OF INDUSTRY FIRSTS



EXPERTS FOR THE REAL WORLD SINCE 1842

1842 CASE is founded.

1869 The first CASE portable steam engine - road construction is born.

1957 The first factory - integrated loader/backhoe in the world: a CASE industry first.

1969 CASE begins skid steer loader production.

1992 Sumitomo becomes supplier to CASE Corporation distributing excavators ranging from 7 to 80 tons.

1998 Global Alliance signed between CASE Corporation and Sumitomo.

2001 CASE introduces the first of its CX excavators, powerful new "thinking machines" designed to enhance productivity through onboard intelligence features.

2007 CX210B is awarded the «Good Design Award» by the design Academy of Japan.

2008 CX210B wins the 18th «Energy Conservation Award» from the

Agency for Natural Resources and Energy of the Japanese Ministry of Economy.

2011 CASE becomes the first construction equipment manufacturer to offer both selective catalytic reduction and cooled exhaust gas recirculation as solutions to meet stringent emissions standards.

2015 CASE launches the new "D series" Tier 4 final/ EU Stage IV Crawler Excavators.

CRAWLER EXCAVATORS D-NA

BUILT TO LAST AND CONTROL



HIGH RELIABILITY

Improved D-esign for D-urable performances

- The boom and arm have been re-designed according to the latest stress analysis criteria, to reduce stress points while maintaining weight optimization to ensure the best lifting performance.
- New high strength casting parts with joined hinge flanges reduce stress and increase durability.
- The undercarriage has been re-designed and re-shaped to facilitate the welding process, enhancing the reliability of the fabricated structures.
- The One-Side-Slope lower frame design reduces the time needed to clean the undercarriage.
- The thickness of the structural plates has been increased, especially in those parts where a high level of protection is required for components.

HIGH QUALITY

Accurate, simple and robust design for high durability

- True to CASE's enviable reputation for reliability and durability, the D-series delivers leading design solutions and manufacturing quality.
- Wide choice of arm solutions, including the Heavy-Duty arm with reinforcement plate and bars on the bottom side.
- Standard Heavy-Duty boom and arm on the CX370D.



HIGH PRECISION AND CONTROLLABILITY

Smooth control with the CASE Intelligent Hydraulic System

The proven CASE Intelligent Hydraulic System (CIHS) delivers energy savings in all cycle time phases (digging, boom up and swing, dumping).

D-SERIES CRAWLER EXCAVATORS



HIGH VERSATILITY

Working modes easily adapt to every work load

The familiar **working mode systems** offers 3 power modes to match different customer needs.

- A** MODE: for grading, lifting and precision work.
- H** MODE: the best balance between productivity and fuel economy.
- SP** MODE: extra speed and power for the most demanding jobs that require maximum productivity.

Auto Power boost automatically increases hydraulic pressure according to the operation's demands.



FAST CYCLES

High Performance Hydraulics control

- The new electrically controlled pumps and a bigger main control valve deliver faster cycle times.
- Oil flow can be adjusted according to working needs, or increased smoothly while starting travel and boom down.
- As a result, the machine responsiveness to operation load is multiplied, resulting in cycle times up to 12% faster than the previous generation.

PRODUCTIVITY BIGGER PERFORMANCE



HIGH EFFICIENCY

Great performances with low fuel consumption

CASE advanced energy management provides solid fuel saving opportunities and lower emissions and helps to prolong the life of the machine. It consists of 5 Energy Saving controls:

- Torque control decreases main pump loads to prevent a drop in engine rpm, with improved sensitivity to control/monitor main pump loads.
- Boom Economy Control (BEC) increased fuel efficiency during boom lower and swing operations, like dump unloading.
- Swing Relief Control (SWC) carefully manages the hydraulic power distribution in slewing operations to deliver the most efficient flow and pressure.
- Spool Stroke Control (SSC) creates an automatic pressure adjustment during digging and leveling operations.
- Idle functions: the Auto Idle function lowers engine rpm after 5 seconds of lever inactivity whatever the throttle position, while the Idle Shutdown function shuts the engine down after a pre-set time of inactivity. Both are manually switchable.



CLEAN AND MAINTENANCE-FREE POWER

EU STAGE IV/TIER4 FINAL compliant CASE engines

- Maintenance-free SCR and DOC-only solution.
- No Diesel Particulate Filter (DPF) or regeneration are required as no solid particles remain trapped into the system, resulting in maximum uptime and lower operating costs.
- The high engine efficiency of the latest generation, electronically controlled, high pressure common rail with multi-injection engine ensures great performance and low fuel consumption.
- CASE adds a Variable Geometry Turbocharger to ensure a fast transient response of the engine while minimizing fluid consumption”.
- The largest Adblue tank in the industry allows the lowest frequency of Adblue refilling and thus a great operator autonomy.

D-SERIES CRAWLER EXCAVATORS



COMFORTABLE AND SAFE CAB

Ergonomic seat design and spacious cab

- Superior cab structure with ample legroom for the operator.
- Fully adjustable workstation.
- New ergonomically designed highback seat with air suspension for excellent comfort.
- Optional seat tilting adjustment and seat heater
- Top class features include 178 mm colour LED Monitor, bluetooth tuner and Radio, spacious storage compartment, 12v accessory plug, clipboard holder, mobile phone holder, warm and cool box, fuse box service connection, storage tray and ergonomic arm rest.



SMOOTH RIDE, QUIET WORK ENVIRONMENT

Soundproof
pressurised cab

The cushioning system lowers noise and vibration levels for the operator's ultimate comfort.



COMFORT RULES FIRST CLASS CAB AND SEAT



D-SERIES CRAWLER EXCAVATORS



SAFE OPERATION

ROPS Cab and FOPS level II

A safe working environment for the operator:

- Reinforced structure of the cab compliant with ROPS/FOPS requirements.
- Standard head protection approved to FOPS Level 2.
- Wide offering of optional front guards.
- Optional factory fitted travel alarm for greater safety on the jobsite around the machine.



OUTSTANDING VISIBILITY

Safety-minded cab structure

Cab designed to create a perceptibly safe and secure working environment:

- Ample glazed surface.
- Rear and side view camera.
- Unique 178 mm LED monitor with continuous camera view.
- Efficient use of space with grouped engine, cooling and after-treatment systems to provide excellent rear visibility.
- Optional LED lighting package provides a deeper and wider visibility coverage of the area around the machine when working after dark.



SAFETY AND MAINTENANCE

WORK SAFELY IN ALL CONDITIONS

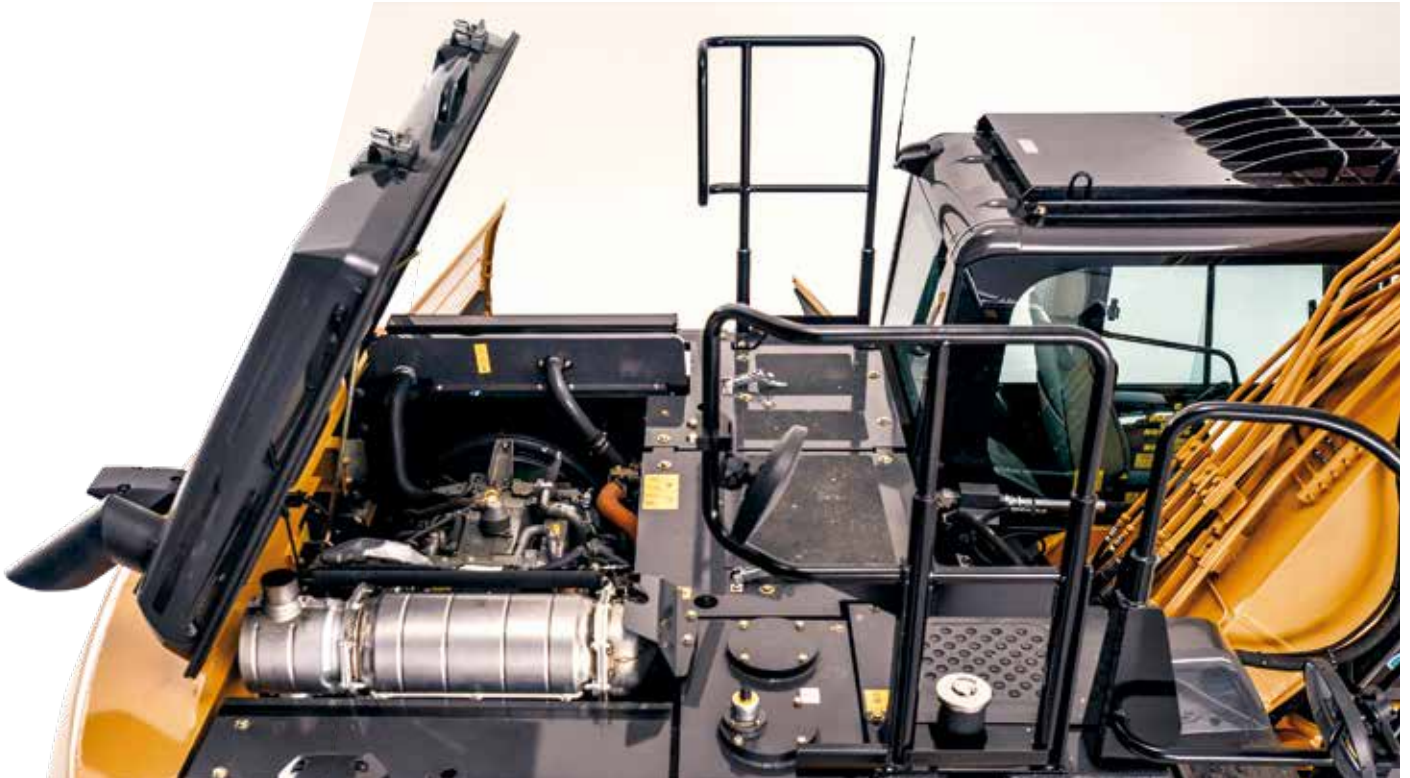

SAFE ACCESS TO UPPERCARRIAGE

Solid and robust platform and handrails

- Wide, robust and comfortable steps or safe access to the top of the hood.
- Solid handrail for protection on the top of the hood.
- Non slip-plates and top hood cover supported by 2 gas pistons and secured by 2 mechanical stops when open.
- A wide platform (up to 60 cm) on top of the engine compartment to work safely on the engine box.



EASY MAINTENANCE

CASE stays «grounded»

- All filters and regular fill points are grouped for easy access.
- Engine oil change intervals set at 500 hours.
- Radiator and cooler cores mounted side by side for easy access for cleaning and more efficient cooling.
- Standard 100 l/min refueling pump with automatic cut off reduces downtime for regular fills.
- Optional hydraulic and engine oil sampling port accessible at ground level for easy oil check.
- Battery Shutdown Switch for safe maintenance on the electrical system.
- All the D-series crawler excavators feature the Extended Maintenance System (EMS) bushings, providing 1,000 hour greasing intervals on all pins except the attachment linkage.



MAIN REASONS TO CHOOSE THE D-SERIES



HIGH EFFICIENCY

- Energy saving system to take advantage of all fuel saving opportunities: up to 8% more fuel efficiency
- High levels of AdBlue autonomy with larger AdBlue tank and low additive consumption



HIGH PRECISION AND CONTROLLABILITY

CASE Intelligent Hydraulic System (CIHS)
Synonymous with high performance
smooth control.



HIGH RELIABILITY

Reliability and durability thanks
to the new redesigned arm,
boom and undercarriage.



FAST CYCLES

- New electronically controlled hydraulic pumps
- New larger main valve





OUTSTANDING VISIBILITY

- Wide glazed area
- Rear and side view cameras
- Large LED monitor
- Optional LED lighting package



SMOOTH RIDE, QUIET WORK ENVIRONMENT

- Cab with cushioning system
- Low noise and vibration



COMFORTABLE AND SAFE CAB

- Extra spacious cab
- Fully adjustable workstation
- New high back seat



CLEAN AND MAINTENANCE-FREE POWER

- EU Stage IV/Tier4 final compliant
- No DPF
- DOC and SCR-only maintenance-free components



SAFE OPERATION AND MAINTENANCE

- ROPS cab and FOPS level II
- Standard extended handrails and guardrails
- Optional factory fitted travel alarm
- Maintenance points grouped for easy and safe access



HIGH VERSATILITY

- 3 available power modes to match customers needs (A, H, SP)
- Auto Power boost job-sensing hydraulic pressure increase.





THE SCIENCE BIT

The CASE SiteWatch telematics system uses a high-tech control unit mounted on each machine to collate information from that machine and from GPS satellites. This data is then sent wirelessly through the mobile communication networks to the CASE Telematics Web Portal.



SiteWatch: centralised fleet control benefits at your fingertips

Measure your true asset availability and optimise it

- Eliminate the “phantom fleet”: SiteWatch allows to identify spare units or under loaded machines on each site.
- Become able to reallocate units where they are more needed.
- Forward Maintenance Planning is easier since the actualised working hours are always available.
- Extend the benefits of SiteWatch to the rest of your fleet: SiteWatch can be installed on the units of other brands as well.

Challenge your Total Cost of Ownership!

- Being able to compare the fuel usage of different machine types will allow you choose the right equipment.
- Save on transport costs with planned and grouped maintenance tasks.
- Peace of mind, optimised uptime and lower repair costs: with preventive maintenance you can for example be alerted if the engine needs to be serviced and avoid a disruptive breakdown.
- Be able to compare your asset Return On Investment on different sites.
- Your equipment is used only during working hours. You can set up alerts so that you know if it is in use during the weekend or at night.
- Integrate with the programmed maintenance package, so that you can be sure every machine is at the right place at the right time.

More Safety, Lower Insurance Premium

- Keep thieves away: dissuade them from attacking your asset because it is geo-localised. SiteWatch is hidden so that thieves can't find it quickly.
- Your fleet is used only where you decide. You can define a virtual fence and receive an email when a machine exits that perimeter.

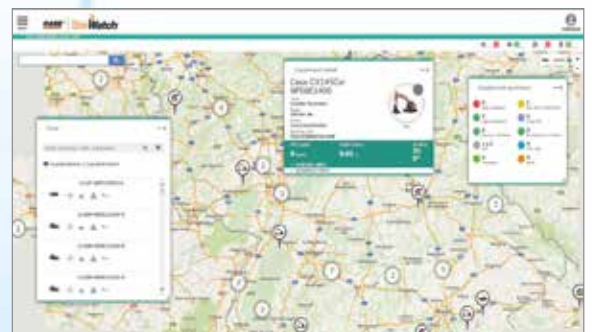

STANDARD AND OPTIONS

STANDARD EQUIPMENT

ENGINE

Isuzu 4 cylinders (CX250D), 6 cylinders (CX300D)
turbo-charged diesel
Tier 4 Final/EU stage IV Certified
Selective Catalytic Reduction (SCR)
Diesel Oxidation Catalyst (DOC)
Cooled Exhaust Gas Recirculation (CEGR)
VGT turbocharger
Electronic fuel injection
High pressure common rail system
Neutral safety start
Auto-engine warm up, emergency stop
Glow-plug pre-heat
Engine Protection Feature (EPF)
Dual-stage fuel filtration
Dual element air filter
Remote oil filter
Green plug oil drain
500-hour engine oil change interval
24-Volt system
Battery disconnect switch
High ambient temperature cooling package
External Fuel and AdBlue gauges
Fuel cooler
Fuel filter restriction indicator
Fuel shut-off valve
Idle start
Radiator, oil cooler, intercooler – protective Screen
Refueling Pump

FUEL ECONOMY SYSTEMS

Engine Idle/Fuel Economy System:
Auto-idle
One-touch idle
Auto-idle shut-down
Torque control
Boom Economy Control (BEC)
Swing Relief Control (SWC)
Spool Stroke Control (SSC)

OPTIONAL EQUIPMENT

HYDRAULICS

Clamshell circuit
Low-flow circuit, proportional control
Single acting pedal activated hammer circuit
Single acting hammer circuit with electrical proportional control
Multifunction (hammer/high flow) circuit with electrical proportional control

ATTACHMENTS

CX250D: arm 2,5 m; 3,52 m
CX300D: 2,65 m; 3,7 m
Hydraulic quick coupler provision
Safety valves and bucket linkage with hook
Heavy Duty Bucket link without hook

HYDRAULICS

Electronically controlled hydraulic pumps
Auto power boost
Auto travel speed change
Selectable work modes
Overload warning device
ISO pattern controls
Pre-set auxiliary pump settings
Switch controlled auxiliary selection
Auxiliary valve
Hydraulic filter restriction indicator
Oil cooler
5,000 hour hydraulic oil change interval
2,000 hour hydraulic filter change interval

UPPERSTRUCTURE

ISO mirrors
Handrail – RH access
Isolation mounted cab (fluid and spring)
Lifting eyes for counterweight
Lockable fuel cap, service doors and toolbox
Rear and side view safety camera

OPERATOR STATION

ROPS protection
FOPS guard OPG level II
Pressurized cab
Tempered safety glass
One-touch lock front window
Sun visor&rain deflector
AC/heat/defrost w/auto climate control
Hot&coolbox, cup holder & ashtray
Interior dome light
Cloth covered air-suspension high-back seat
Sliding seat – 90 mm
Seat-belt
Adjustable armrests
Tilting consoles - 4-position
Low-effort joystick controls

OPERATOR STATION

Air suspension heated and tilt seat
Front cab guard - vertical bars (OPG level 2)
Front cab guard - vertical bars (OPG level 1)
Front mesh screen
Travel alarm
AM/FM CD/radio with antenna and 2-speakers
LED working lights
Side view camera with LED lights (right and left)
CMVM (Case Maxi View Monitor)

Sliding cockpit 180 mm
Auxiliary select system
Aux-in port for personal electronics
Multifunction LED color monitor (180 mm)
26 selectable languages for monitor
Anti-theft system (start code system)
Rubber floor mat
12-volt electric socket
24-volt cigarette lighter
One-piece right hand window
Working lights (boom&upperstructure)
Cab top working lights
Windshield wiper / washer
Clear (Lexan) roof window w/sunshade
Storage compartments
On-board diagnostic system

ATTACHMENTS

Standard boom 5850 mm (CX250D)
10300 mm (CX250D LR)
Standard boom 6150 mm (CX300D)
CX250D: arm 3.0 m
CX250D LR: arm 8.0 m
CX300D: arm 3.2 m
Auxiliary pipe brackets
Centralized lube bank
Attachment cushion valve

UNDERCARRIAGE

600 mm steel triple grouser shoes
Sealed link chain
Lashing points

UNDERCARRIAGE

700 mm steel triple grouser shoes
800 mm steel triple grouser shoes
(all models versions except CX250D LR)
900 mm steel triple grouser shoes
(only for CX300D LC and CX250D LR)
Track guide single

TELEMATICS AND OTHERS

Three years SiteWatch “Advanced” subscription with remote monitoring and one user’s licence
Pre cleaner /cyclone type (except for CX250D LR)
Engine oil and hydraulic oil sample port
Reversible Variable angle fan (only for CX250D LR)

CX D-SERIES

CX250D LC-NLC

ENGINE

Model _____ ISUZU AQ-4HK1X
 Type _____ Water-cooled, 4-cycle
 diesel, 4-cylinder in line, High pressure common rail system (electric control), Turbocharger with air cooled intercooler, SCR system.
 Number of cylinders / Displacement (l) _____ 4 / 5,52
 Emissions level _____ Tier 4 final / Eu stage IV
 Bore & stroke (mm) _____ 115 x 125

Rated flywheel horse power
 SAE J1349, ISO 9249 _____ 132.1 kW / 177 hp at 2000 min⁻¹
 ISO 14396 _____ 140 kW / 188 hp at 2000 min⁻¹

Maximum torque
 SAE J 1349, ISO 9249 _____ 621 N-m at 1800 min⁻¹
 ISO 14396 _____ 642 N-m at 1800 min⁻¹

HYDRAULIC SYSTEM

Main pumps _____ 2 variable displacement axial piston pumps with regulating system
 Max. oil flow _____ 2 x 234 l/min at 2000 min⁻¹

Working circuit pressure
 Boom/Arm/Bucket _____ 34.3 MPa - 37.3 MPa with auto power boost
 Swing circuit _____ 28.9 MPa
 Travel circuit _____ 34.3 MPa
 Pilot pump _____ 1 gear pump
 Max. oil flow (l/min) _____ 20
 Working circuit pressure _____ 3.9 MPa

Boom Cylinders
 Bore _____ 130 mm
 Stroke _____ 1335 mm

Arm Cylinder
 Bore _____ 145 mm
 Stroke _____ 1660 mm

Bucket Cylinder
 Bore _____ 130 mm
 Stroke _____ 1070 mm

SWING

Swing Motor _____ Fixed displacement axial piston motor
 Maximum swing speed _____ 10.6 min⁻¹
 Swing torque _____ 74,900 Nm

PERFORMANCE DATA

		Arm 3.00 m	Arm 2.50 m	Arm 3.52 m
Boom length	mm	5850	5850	5850
Bucket radius	mm	1570	1570	1570
Bucket wrist action	°	175°	175°	175°
A Maximum reach at GRP	mm	10100	9630	10620
B Maximum reach	mm	10280	9820	10790
C Max. digging depth	mm	6900	6400	7420
D Max. digging height	mm	9760	9560	10070
E Max. dumping height	mm	6760	6550	7060
F Min. swing radius	mm	4030	3980	4050

DIGGING FORCE (ISO 6015)

		Arm 3.00 m	Arm 2.50 m	Arm 3.52 m
Arm digging force	kN	120	141	107
with Auto power boost	kN	130	153	116
Bucket digging force	kN	162	162	162
with Auto power boost	kN	176	176	176

FILTERS

Suction filter _____ 105 µm
 Return filter _____ 6 µm
 Pilot line filter _____ 8 µm

ELECTRICAL SYSTEM

Voltage _____ 24 V
 Alternator _____ 50 Amp
 Starter _____ 24 V 5.0 kW
 Battery _____ 2X12V 128 Ah/5 HR

UNDERCARRIAGE

Travel motor _____ Variable displacement axial piston motor
 High travel speed (Automatic travel speed shifting) (km/h) _____ 5.5
 Low travel speed (km/h) _____ 3.5
 Drawbar pull (kN) _____ 200
 Number of carrier rollers (each side) _____ 2
 Number of track rollers (each side) _____ 9
 Number of shoes (each side) _____ 51
 Type of shoes _____ Triple grouser shoes
 Grade ability _____ 70 % (35°)

SOUND LEVEL

External guaranteed sound level
 (EU Directive 2000/14/EC) _____ LwA 102 dB(A)
 Operator cab sound pressure level (ISO 6396) _____ LpA 70 dB(A)

CIRCUIT AND COMPONENT CAPACITIES

Fuel tank _____ 410 l
 Hydraulic system _____ 250 l
 Hydraulic tank _____ 147 l
 Adblue tank _____ 120 l

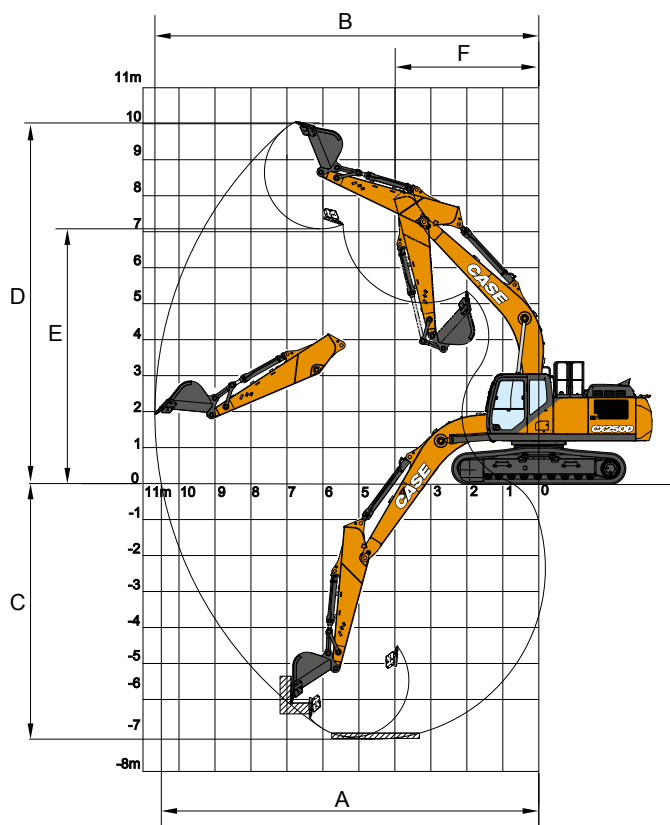

SPECIFICATIONS

GENERAL DIMENSIONS

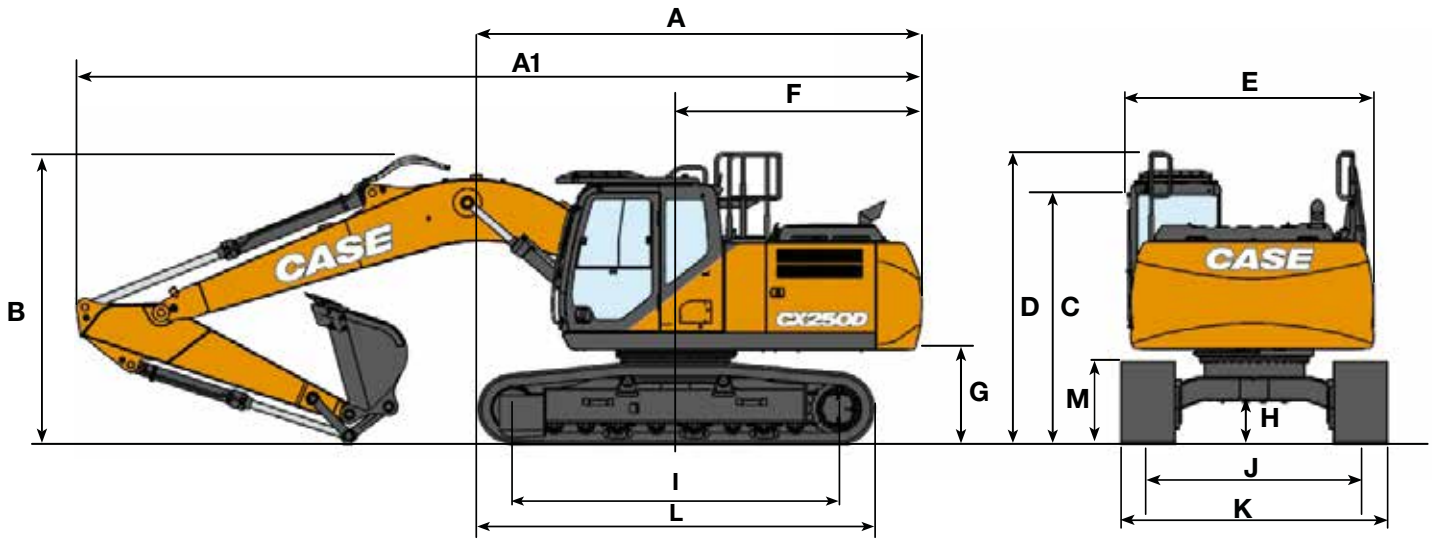

		Arm 3.00 m	HD arm 2.50 m	Arm 3.52 m	
A	Overall length (without attachment)	mm	5270	5270	5270
A1	Overall length (with attachment)	mm	9880	9950	9910
B	Overall height (to top of boom)	mm	3200	3350	3360
C	Cab height	mm	3130	3130	3130
D	Overall height (to top of guardrail)	mm	3340	3340	3340
E	Upper structure overall width (LC/NLC)	mm	2770	2770	2770
F	Swing (rear end radius)	mm	2950	2950	2950
G	Clearance height under upper structure	mm	1100	1100	1100
H	Minimum ground clearance	mm	440	440	440
I	Wheel base (Center to center of wheels)	mm	3840	3840	3840
L	Crawler overall length	mm	4650	4650	4650
M	Crawler tracks height	mm	940	940	940
J	Track gauge (LC/NLC)	mm	2590 / 2390	2590 / 2390	2590 / 2390
K	Undercarriage overall width (LC/NLC with 600 mm shoes)	mm	3190 / 2990	3190 / 2990	3190 / 2990

WEIGHT AND GROUND PRESSURE

With 3.00 m Arm, 1.1 m³ bucket, operator, lubricant, coolant, full fuel tank and FOPS protection level 2.

LC	Weight	Ground pressure
600 mm grouser shoes	25.400 kg	0.050 MPa
700 mm grouser shoes	25.700 kg	0.044 MPa
800 mm grouser shoes	26.000 kg	0.039 MPa
900 mm grouser shoes	26.400 kg	0.035 MPa

NLC	Weight	Ground pressure
600 mm grouser shoes	25.300 kg	0.050 MPa
700 mm grouser shoes	25.600 kg	0.043 MPa

Counterweight 5.220 kg

LIFTING CAPACITY

CX250D LC-NLC

Front Side	REACH									
	2.0 m		4.0 m		6.0 m		8.0 m		At max reach	

LC UNDERCARRIAGE - Standard arm 3.00 m, 600 mm shoes, max reach 8.71 m

8.0 m					5560*	5560*			4700*	4700*	6.17
6.0 m									4200*	4200*	7.67
4.0 m					7600*	6790	6290	4360	4120*	3980	8.45
2.0 m			14220*	11460	9140*	6360	6120	4200	4320*	3700	8.71
0 m			16030*	10880	9150	6050	5980	4070	4850*	3750	8.5
-2.0 m	10350*	10350*	15580*	10820	9040	5950			6000*	4220	7.77
-4.0 m	19880*	19880*	13140*	11070	8620*	6100			7770*	5660	6.37

LC UNDERCARRIAGE - Short arm 2.50 m, 600 mm shoes, max reach 8.25 m

8.0 m									6920*	6920*	5.5
6.0 m					7100*	7020			6070*	5260	7.14
4.0 m			11180*	11180*	8120*	6700			5950*	4320	7.97
2.0 m					9420	6290	6090	4180	5820	4000	8.24
0 m			14210*	10840	9130	6030	6000	4090	5980	4080	8.02
-2.0 m	10880*	10880*	15100*	10880	9080	5980			6910	4680	7.25
-4.0 m			11990*	11220					8000*	6670	5.72

LC UNDERCARRIAGE - Long arm 3.52 m, 600 mm shoes, max reach 9.21 m

8.0 m									3740*	3740*	6.87
6.0 m							4500*	4480	3370*	3370*	8.24
4.0 m					6980*	6870	6270*	4380	3300*	3300*	8.97
2.0 m			13130*	11660	8630*	6390	6110	4190	3440*	3370	9.21
0 m			15640*	10860	9140	6020	5940	4030	3810*	3400	9.01
-2.0 m	9280*	9280*	15790*	10690	8960	5870	5880	3970	4580*	3770	8.34
-4.0 m	16710*	16710*	13980*	10860	9040	5940			6460*	4820	7.05

NLC UNDERCARRIAGE - Standard arm 3.00 m, 600 mm shoes, max reach 8.71 m

8.0 m					5560*	5560*			4700*	4700*	6.17
6.0 m									4200*	4200*	7.67
4.0 m					7600*	6240	6270	4010	4120*	3650	8.45
2.0 m			14220*	10330	9140*	5820	6100	3850	4320*	3390	8.71
0 m			16030*	9770	9130	5510	5960	3730	4850*	3430	8.5
-2.0 m	10350*	10350*	15580*	9720	9010	5420			6000	3860	7.77
-4.0 m	19880*	19880*	13140*	9960	8620	5570			7770*	5170	6.37

NLC UNDERCARRIAGE - Short arm 2.50 m, 600 mm shoes, max reach 8.25 m

8.0 m									6920*	6920*	5.5
6.0 m					7100*	6470			6070*	4840	7.14
4.0 m			11180*	11180*	8120*	6150			5950*	3970	7.97
2.0 m					9400	5750	6070	3830	5800	3660	8.24
0 m			14210*	9740	9100	5490	5980	3740	5960	3730	8.02
-2.0 m	10880*	10880*	15100*	9780	9050	5450			6890	4280	7.25
-4.0 m			11990*	10100					8000*	6090	5.72

NLC UNDERCARRIAGE - Long arm 3.52 m, 600 mm shoes, max reach 9.21 m

8.0 m									3740*	3740*	6.87
6.0 m							4500*	4120	3370*	3370*	8.24
4.0 m					6980*	6310	6270*	4020	3300*	3300*	8.97
2.0 m			13130*	10520	8630*	5850	6100	3840	3440*	3080	9.21
0 m			15640*	9760	9110	5490	5920	3680	3810*	3110	9.01
-2.0 m	9280*	9280*	15790*	9590	8930	5330	5860	3630	4580*	3440	8.34
-4.0 m	16710*	16710*	13980*	9750	9020	5410			6460*	4410	7.05

* The above loads (kg) are compliant to the ISO standards and refer to the excavator equipped without bucket. The indicated loads are no more than 87% of hydraulic system lift capacity or 75% of static tipping load. Values marked with an asterisk (*) are limited by the hydraulic lifting capacity.

BUCKETS

CX250D LC-NLC

CX250D LC

HEAVY DUTY BUCKET (PIN ON)

CAPACITY m ³ (ISO7451 HEAPED)	WIDTH mm	WEIGHT kg	ARM 2.50 m	ARM 3.00 m	ARM 3.52 m
0.48	600	710	○	○	○
0.66	750	790	○	○	○
0.84	900	880	○	○	○
1.06	1100	1020	○	○	●
1.20	1200	1030	○	●	■
1.40	1350	1120	●	■	×
1.62	1500	1200	■	■	×
1.85(*)	1700	1320	■	×	×

(*) not suitable for digging application

ROCK BUCKET (PIN ON)

0.48	600	780	○	○	○
0.66	750	840	○	○	○
0.84	900	920	○	○	○
1.06	1100	1050	○	○	●
1.20	1200	1080	○	●	■
1.40	1350	1180	●	■	×
1.62	1500	1250	■	■	×

DITCH CLEANING BUCKET (PIN ON)

0.89 (**)	1830	760	○	○	○
		910 (*)	○	○	○
1.48 (**)	2130	830	●	●	■
		1020 (*)	●	■	×

TILTABLE DITCH CLEANING BUCKET (PIN ON)

1.13	1800	1100	○	●	■
1.26	2000	1160	●	■	×
1.39	2200	1250	■	■	×
1.51	2400	1310	■	×	×
1.58	2500	1370	■	×	×

Tilt angle 45° L/R - Connect to Low-Flow Auxiliary Hydraulic Circuit

HD SCOOP BUCKET (QUICK COUPLED)

0.48	600	710	○	○	○
0.66	750	770	○	○	○
0.84	900	860	○	○	●
1.06	1100	960	○	●	■
1.20	1200	1020	●	■	×
1.40	1350	1100	■	■	×
1.62	1500	1180	■	×	×

ROCK SCOOP BUCKET (QUICK COUPLED)

0.48	600	760	○	○	○
0.66	750	820	○	○	○
0.84	900	910	○	○	■
1.06	1100	1020	●	●	×
1.20	1200	1060	●	■	×
1.40	1350	1160	■	×	×

FP DITCH CLEANING BUCKET (QUICK COUPLED)

0.89 (**)	1830	810	○	○	●
		970 (*)	○	○	■
1.48	2130	890	■	■	×
		1080 (*)	■	×	×

(*) with bolt-on cutting edge (**) to be removed for road transport with 3.52 m arm
○ Rated material density up to 2 ton/m³ ● Rated material density up to 1.6 ton/m³

CX250D NLC

HEAVY DUTY BUCKET (PIN ON)

CAPACITY m ³ (ISO7451 HEAPED)	WIDTH mm	WEIGHT kg	ARM 2.50 m	ARM 3.00 m	ARM 3.52 m
0.48	600	710	○	○	○
0.66	750	790	○	○	○
0.84	900	880	○	○	○
1.06	1100	1020	○	●	■
1.20	1200	1030	●	●	■
1.40	1350	1120	●	■	×
1.62	1500	1200	■	×	×

ROCK BUCKET (PIN ON)

0.48	600	780	○	○	○
0.66	750	840	○	○	○
0.84	900	920	○	○	○
1.06	1100	1050	○	●	■
1.20	1200	1080	●	●	■
1.40	1350	1180	■	■	×
1.62	1500	1250	■	×	×

DITCH CLEANING BUCKET (PIN ON)

0.89 (**)	1830	760	○	○	○
		910 (*)	○	○	○
1.48 (**)	2130	830	●	■	■
		1020 (*)	■	■	×

TILTABLE DITCH CLEANING BUCKET (PIN ON)

1.13	1800	1100	●	●	■
1.26	2000	1160	■	■	×
1.39	2200	1250	■	■	×
1.51	2400	1310	■	×	×

Tilt angle 45° L/R - Connect to Low-Flow Auxiliary Hydraulic Circuit

HD SCOOP BUCKET (QUICK COUPLED)

0.48	600	710	○	○	○
0.66	750	770	○	○	○
0.84	900	860	○	○	■
1.06	1100	960	●	■	×
1.20	1200	1020	■	■	×
1.40	1350	1100	■	×	×

ROCK SCOOP BUCKET (QUICK COUPLED)

0.48	600	760	○	○	○
0.66	750	820	○	○	○
0.84	900	910	○	○	■
1.06	1100	1020	●	■	×
1.20	1200	1060	■	■	×
1.40	1350	1160	■	×	×

FP DITCH CLEANING BUCKET (QUICK COUPLED)

0.89 (**)	1830	810	○	○	■
		970 (*)	○	●	■
1.48	2130	890	■	×	×
		1080 (*)	■	×	×

■ Rated material density up to 1.2 ton/m³ × Not applicable

CX D-SERIES

CX250D LONG REACH

GENERAL DIMENSIONS

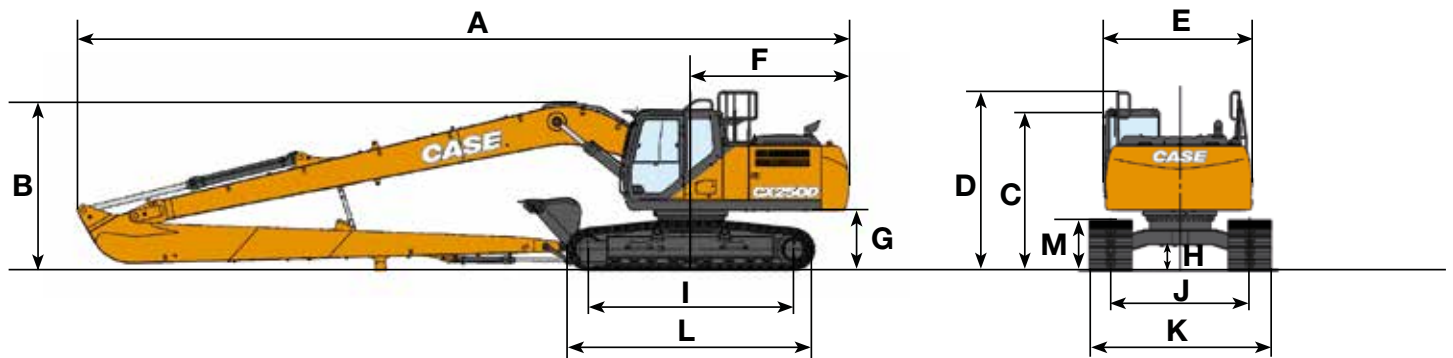

		Arm 8.00 m
Overall length (without attachment)	mm	5270
A Overall length (with attachment)	mm	14380
B Overall height (to top of boom)	mm	3130
C Cab height	mm	3020
D Overall height (to top of handrail)	mm	3220
E Upper structure overall width	mm	2770
F Swing (rear end radius)	mm	2950
G Clearance height under upper structure	mm	1100
H Minimum ground clearance	mm	440
I Wheel base (Center to center of wheels)	mm	3840
L Crawler overall length	mm	4650
M Crawler tracks height	mm	940
J Track gauge	mm	2590
K Undercarriage overall width (LC with 800 mm shoes)	mm	3390

PERFORMANCE DATA

		Arm 8.00 m
Boom length	mm	10300
Bucket radius	mm	1200
Bucket wrist action	°	178
A Maximum reach at GRP	mm	18220
B Maximum reach	mm	18320
C Max. digging depth	mm	14560
D Max. digging height	mm	13950
E Max. dumping height	mm	11780
F Min. swing radius	mm	6220

WEIGHT AND GROUND PRESSURE

With 8.00 m Arm, 0.37 m³ bucket, operator, lubricant, coolant, full fuel tank and FOPS protection level 2.

	Weight	Ground pressure
800 mm grouser shoes	28.100 kg	0.042 MPa

Counterweight 7.350 kg

DIGGING FORCE (ISO 6015)

	Arm 8.00 m
Arm digging force	40.0 kN
Bucket digging force	77 kN

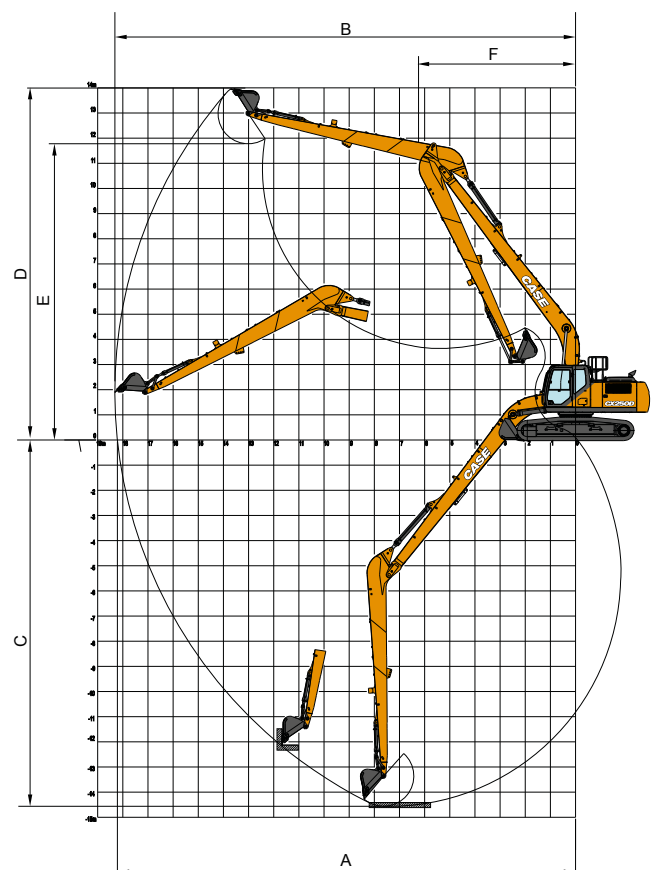

LIFTING CAPACITY

CX250D LONG REACH

Front Side	REACH										
	0.0 m	2.0 m	4.0 m	6.0 m	8.0 m	10.0 m	12.0 m	14.0 m	16.0 m	At max reach	m

LR UNDERCARRIAGE - Super long arm 8.00 m, 800 mm shoes, max reach 17.10 m

12.0 m																			1750*	1750*	13.79								
10.0 m																			1980*	1980*	15.06								
8.0 m																			2040*	2040*	15.98								
6.0 m																			2170*	2170*	16.61								
4.0 m																			2260*	2260*	16.61								
2.0 m																			2340*	2340*	16.98								
0 m																			2540*	2540*	17.11								
-2.0 m																			2090	2220*	1580	1790*	1370	16.98					
-4.0 m																			2550*	2550*	1940	2330	1490	1900*	1280	17.11			
-6.0 m																			2750*	1800	2240	1400	2010	1240	17.01				
-8.0 m																			2170*	2170*	2120*	1660	1730*	1510	16.61				
-10.0 m																			2260*	2260*	2170*	2170*	2120*	1660	1730*	1510	16.61		
-12.0 m																			2540*	2540*	2340*	2090	2220*	1580	1790*	1370	16.98		
																			2830*	2830*	2540*	2540*	2340*	2090	2220*	1580	1790*	1370	16.98
																			3310*	3310*	2850*	2550	2550*	1940	2330	1490	1900*	1280	17.11
																			3780*	3060	3160*	2330	2750*	1800	2240	1400	2010	1240	17.01
																			4170*	2780	3350	2140	2670	1680	2170	1330	2030	1240	16.66
																			4140	2600	3220	2020	2580	1600	2130	1300	2120	1290	16.06
																			4050	2520	3150	1950	2550	1570			2290	1400	15.17
																			4060	2520	3160	1960					2600	1620	13.97
																			4160	2620	3270	2070					3190	2020	12.26
																											3470*	2890	9.91

BUCKETS

CX250D LONG REACH

GENERAL PURPOSE BUCKET (PIN ON)

CAPACITY m ³ (ISO7451 HEAPED)	WIDTH mm	WEIGHT kg	ARM 8.00 m
0.21	450	250	○
0.31	600	290	○
0.41	750	330	○
0.52	900	360	●

GP SCOOP BUCKET (QUICK COUPLED)

CAPACITY m ³ (ISO7451 HEAPED)	WIDTH mm	WEIGHT kg	ARM 8.00 m
0.21	450	250	○
0.31	600	280	○
0.41	750	310	○
0.52	900	360	■

DITCH CLEANING BUCKET (PIN ON)

(**) 0.54	1830	350	●
		4810 (*)	●

FP DITCH CLEANING BUCKET (QUICK COUPLED)

(**) 0.54	1830	370	■
		500 (*)	■

TILTABLE DITCH CLEANING BUCKET (PIN ON)

0.46	1500	640	■
------	------	-----	---

Tilt angle 45° L/R - Connect to Low-Flow Auxiliary Hydraulic Circuit

(*) with bolt-on cutting edge (**) to be removed for road transport

○ Rated material density up to 2 ton/m³ ● Rated material density up to 1.6 ton/m³ ■ Rated material density up to 1.2 ton/m³

CX D-SERIES

CX300D LC-NLC

ENGINE

Model _____ ISUZU AQ-6HK1X
 Type _____ Water-cooled, 4-cycle diesel, 6-cylinder in line, High pressure common rail system (electric control), Turbocharger with air cooled intercooler, SCR system.
 Number of cylinders / Displacement _____ 6 / 7,79 l
 Bore & stroke _____ 115 mm x 125 mm
Rated flywheel horse power
 SAE J1349, ISO 9249 _____ 154 kW / 206 hp at 1800 min⁻¹
 ISO 14396 _____ 161 kW / 216 hp at 1800 min⁻¹
Maximum torque
 SAE J 1349, ISO 9249 _____ 849 Nm at 1500 min⁻¹
 ISO 14396 _____ 880 Nm at 1500 min⁻¹

HYDRAULIC SYSTEM

Main pumps _____ 2 variable displacement axial piston pumps with regulating system
 Max. oil flow _____ 2 x 243 liter/min at 1800 min⁻¹
Working circuit pressure
 Boom/Arm/Bucket _ 34.3 MPa - 37.3 MPa with auto power boost
 Swing circuit _____ 30.4 MPa
 Travel circuit _____ 34.3 MPa
 Pilot pump _____ 27 liter/min
 Working circuit pressure _____ 3.9 MPa
Boom Cylinders
 Bore _____ 140 mm
 Stroke _____ 1369 mm
Arm Cylinder
 Bore _____ 150 mm
 Stroke _____ 1650 mm
Bucket Cylinder
 Bore _____ 135 mm
 Stroke _____ 1078 mm

SWING

Swing Motor _____ Fixed displacement axial piston motor
 Maximum swing speed _____ 10.0 min⁻¹
 Swing torque _____ 92,400 Nm

PERFORMANCE DATA CX300D

		Arm 3.2 m	Arm 2.65 m	Arm 3.7 m
Boom length	mm	6150	6150	6150
Bucket radius	mm	1570	1570	1570
Bucket wrist action		176°	176°	176°
A Maximum reach at GRP	mm	10490	10030	10980
B Maximum reach	mm	10670	10220	11160
C Max. digging depth	mm	7100	6570	7580
D Max. digging height	mm	10050	9930	10390
E Max. dumping height	mm	7080	6930	7390
F Min. swing radius	mm	4030	3980	4080

DIGGING FORCE (ISO 6015)

		Arm 3.2 m	Arm 2.65 m	Arm 3.7 m
Arm digging force	kN	128.4	147.0	114.3
with Auto power boost	kN	139.6	159.9	124.3
Bucket digging force	kN	175.0	175.0	175.0
with Auto power boost	kN	190.3	190.3	190.3

FILTERS

Suction filter _____ 105 µm
 Return filter _____ 6 µm
 Pilot line filter _____ 8 µm

ELECTRICAL SYSTEM

Voltage _____ 24 V
 Alternator _____ 50 Amp
 Starter _____ 24 V 5.0 kW
 Battery _____ 2X12V 128 Ah/5 HR

UNDERCARRIAGE

Travel motor _____ Variable displacement axial piston motor
 High travel speed (Automatic travel speed shifting) _____ 5.4 km/h
 Low travel speed _____ 3.2 km/h
 Drawbar pull _____ 233 KN
 Number of carrier rollers (each side) _____ 2
 Number of track rollers (each side) _____ 9
 Number of shoes (each side) _____ 50
 Type of shoes _____ Triple grouser shoes
 Grade ability _____ 70 % (35°)

SOUND LEVEL

External guaranteed sound level
 (EU Directive 2000/14/EC) _____ LwA 102 dB(A)
 Operator cab sound pressure level (ISO 6396) _____ LpA 70 dB(A)

CIRCUIT AND COMPONENT CAPACITIES

Fuel tank _____ 457 l
 Hydraulic system _____ 300 l
 Hydraulic tank _____ 147 l
 Adblue tank _____ 120 l

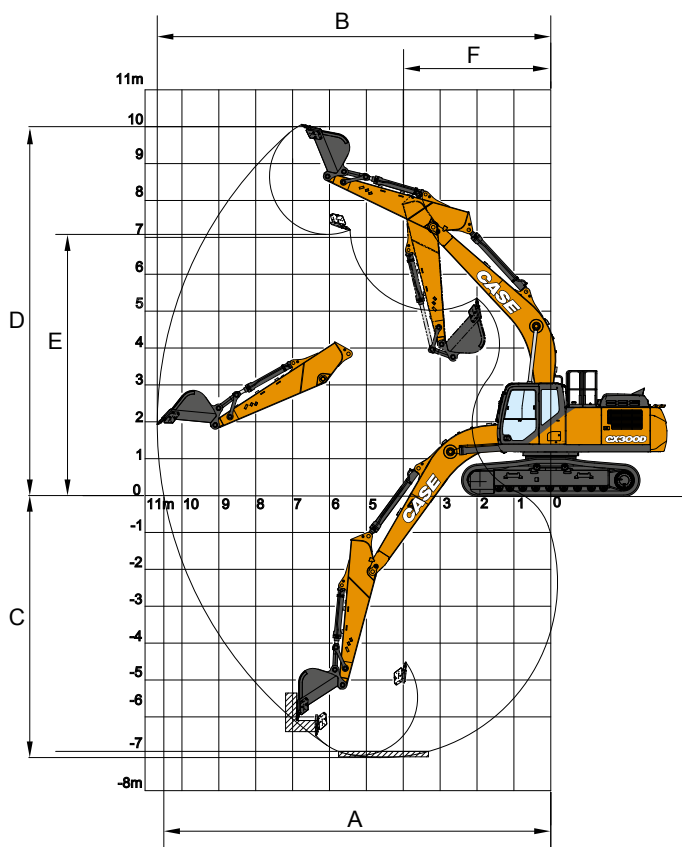

GENERAL DIMENSIONS

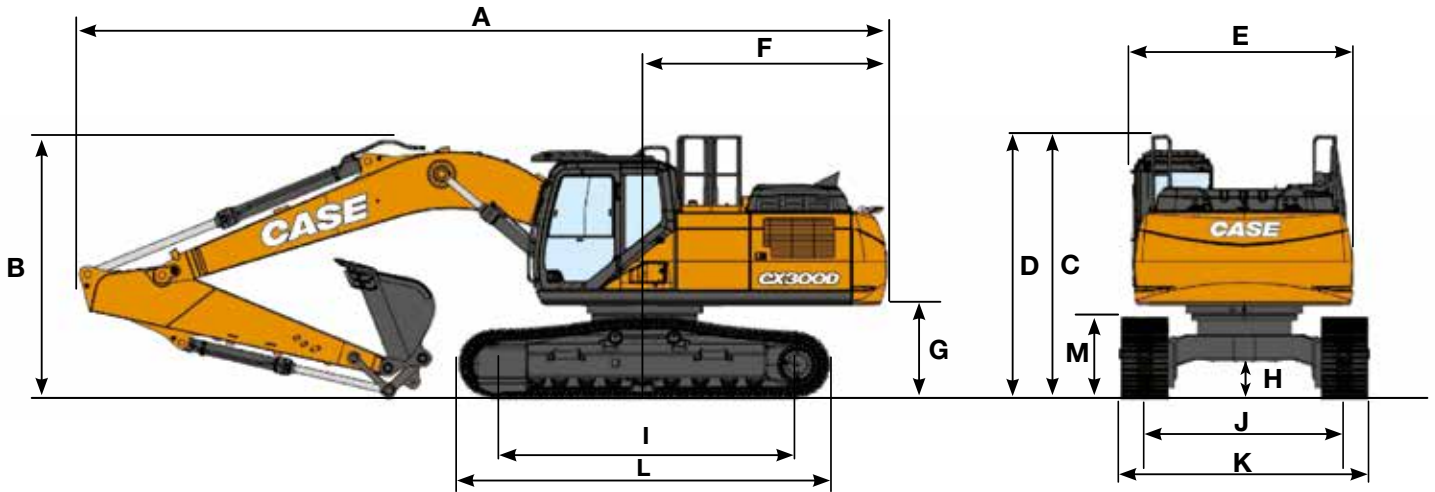

LC/NLC		Arm 3.2 m	Arm 2.65 m	Arm 3.7 m
	Overall length (without attachment)	mm	5580	5580
A	Overall length (with attachment)	mm	10510	10520
B	Overall height (to top of boom)	mm	3350	3340
C	Cab height	mm	3210	3210
D	Overall height (to top of guardrail)	mm	3420	3420
E	Upper structure overall width	mm	2890	2890
F	Swing (rear end radius)	mm	3160	3160
G	Clearance height under upper structure	mm	1190	1190
H	Minimum ground clearance	mm	460	460
I	Wheel base (Center to center of wheels)	mm	3980	3980
L	Crawler overall length	mm	4850	4850
M	Crawler tracks height	mm	1040	1040
LC				
		Arm 3.2 m	Arm 2.65 m	Arm 3.7 m
J	Track gauge	mm	2600	2600
K	Undercarriage overall width (with 600 mm shoes)	mm	3200	3200
NLC				
		Arm 3.2 m	Arm 2.65 m	Arm 3.7 m
J	Track gauge	mm	2390	2390
K	Undercarriage overall width (with 600 mm shoes)	mm	2990	2990

WEIGHT AND GROUND PRESSURE CX3000

with 3.20 m Arm, 1.1 m³ bucket, 600 mm grouser shoe, operator, lubricant, coolant, full fuel tank and FOPS protection level 2.

CX3000 LC	Weight	Ground pressure
	30.000 kg	0.057 MPa

CX3000 NLC	Weight	Ground pressure
	29.900 kg	0.057 MPa

Counterweight 5.100 kg

LIFTING CAPACITY

CX300D LC-NLC

REACH	2.0 m		4.0 m		6.0 m		8.0 m		At max reach		m
	Front	Side	Front	Side	Front	Side	Front	Side	Front	Side	

LC UNDERCARRIAGE - Standard arm 3.2 m, 600 mm shoes, max reach 9.10 m

8.0 m									6080*	6080*	6.72
6.0 m							6310*	5410	5690*	5270	8.12
4.0 m			13320*	13320*	9620*	8160	7810	5270	5730*	4480	8.85
2.0 m			15990*	13640	11380*	7610	7560	5050	6130*	4180	9.1
0 m			13740*	12990	11310	7230	7370	4870	6340	4220	8.89
-2.0 m	9910*	9910*	18170*	12940	11150	7090	7310	4830	7080	4690	8.19
-4.0 m	18660*	18660*	14910*	13190	10250*	7210			8430*	6060	6.85

LC UNDERCARRIAGE - Short arm 2.65 m, 600 mm shoes, max reach 8.65 m

8.0 m					8450*	8450*			7930*	7930*	6.1
6.0 m					8930*	8530			7290*	5820	7.61
4.0 m			14840*	14840*	10290*	8090	7790	5270	7210	4880	8.39
2.0 m					11710	7590	7580	5080	6750	4540	8.65
0 m			11770*	11770*	11350	7270	7430	4940	6910	4610	8.43
-2.0 m	10260*	10260*	17430*	13130	11270	7200			7860	5210	7.69
-4.0 m			13510*	13460	9170*	7420			8550*	7050	6.24

LC UNDERCARRIAGE - Long arm 3.7 m, 600 mm shoes, max reach 9.58 m

8.0 m									4870*	4870*	7.37
6.0 m							6530*	5460	4560*	4560*	8.66
4.0 m					8970*	8240	7690*	5280	4570*	4090	9.35
2.0 m			16920*	13850	10850*	7640	7550	5030	4820*	3820	9.58
0 m			14380*	12940	11270	7190	7310	4820	5410*	3850	9.39
-2.0 m	8860*	8860*	18580*	12760	11050	6990	7210	4720	6390	4220	8.73
-4.0 m	15850*	15850*	15920*	12940	10870*	7050			7970*	5260	7.49
-6.0 m									8010*	8010*	4.86

NLC UNDERCARRIAGE - Standard arm 3.2 m, 600 mm shoes, max reach 9.10 m

8.0 m									6080*	6080*	6.72
6.0 m							6310*	4970	5690*	4840	8.12
4.0 m			13320*	13320*	9620*	7480	7790	4840	5730*	4110	8.85
2.0 m			15990*	12240	11380*	6940	7550	4620	6130*	3820	9.1
0 m			13740*	11610	11280	6560	7350	4450	6320	3850	8.89
-2.0 m	9910*	9910*	18170*	11560	11130	6430	7300	4400	7070	4270	8.19
-4.0 m	18660*	18660*	14910*	11810	10250*	6550			8430*	5520	6.85

NLC UNDERCARRIAGE - Short arm 2.65 m, 600 mm shoes, max reach 8.65 m

8.0 m					8450*	7910			7930*	7690	6.1
6.0 m					8930*	7840			7290*	5350	7.61
4.0 m			14840*	13460	10290*	7410	7770	4830	7200	4480	8.39
2.0 m					11690	6920	7570	4650	6740	4160	8.65
0 m			11770*	11700	11320	6610	7410	4510	6890	4220	8.43
-2.0 m	10260*	10260*	17430*	11750	11240	6540			7840	4750	7.69
-4.0 m			13510*	12070	9170*	6750			8550*	6430	6.24

NLC UNDERCARRIAGE - Long arm 3.7 m, 600 mm shoes, max reach 9.58 m

8.0 m									4870*	4870*	7.37
6.0 m							6530*	5020	4560*	4360	8.66
4.0 m					8970*	7550	7960*	4850	4570*	3740	9.35
2.0 m			16920*	12430	10850*	6970	7530	4600	4820*	3490	9.58
0 m			14380*	11560	11250	6520	7300	4390	5410*	3500	9.39
-2.0 m	8860*	8860*	18580*	11380	11020	6330	7190	4290	6380	3840	8.73
-4.0 m	15850*	15850*	15920*	11560	10870*	6380			7970*	4780	7.49
-6.0 m									8010*	8010*	4.86

* The above loads (kg) are compliant to the ISO standards and refer to the excavator equipped without bucket. The indicated loads are no more than 87% of hydraulic system lift capacity or 75% of static tipping load. Values marked with an asterisk (*) are limited by the hydraulic lifting capacity.

BUCKETS

CX300D LC-NLC

CX300D LC

HEAVY DUTY BUCKET (PIN ON)

CAPACITY m ³ (ISO7451 HEAPED)	WIDTH mm	WEIGHT kg	ARM 2.65 m	ARM 3.18 m	ARM 3.66 m
0.85	900	1040	○	○	○
1.11	1100	1150	○	○	○
1.24	1200	1240	○	○	○
1.43	1350	1310	●	●	■
1.63	1500	1460	●	●	■
1.88 (*)	1700	1570	■	■	×

(*) not suitable for digging application

ROCK BUCKET (PIN ON)

0.85	900	1080	○	○	○
1.11	1100	1190	○	○	○
1.24	1200	1280	○	○	●
1.43	1350	1360	●	●	■
1.63	1500	1500	●	■	■

DITCH CLEANING BUCKET (PIN ON)

0.89 (**)	1830	760	○	○	○
		910 (*)	○	○	○
1.48 (**)	2130	830	○	○	●
		1020 (*)	○	●	●

TILTABLE DITCH CLEANING BUCKET (PIN ON)

1.13	1800	1100	○	○	●
1.26	2000	1160	○	●	●
1.39	2200	1250	●	●	■
1.51	2400	1310	●	■	■
1.58	2500	1370	■	■	■

Tilt angle 45° L/R - Connect to Low-Flow Auxiliary Hydraulic Circuit

HD SCOOP BUCKET (QUICK COUPLED)

0.85	900	1030	○	○	○
1.11	1100	1140	○	●	●
1.24	1200	1230	●	●	■
1.43	1350	1310	●	■	■
1.63	1500	1450	■	×	×

ROCK SCOOP BUCKET (QUICK COUPLED)

0.85	900	1070	○	○	○
1.11	1100	1180	○	●	●
1.24	1200	1270	●	●	■
1.43	1350	1350	■	■	×
1.63	1500	1490	■	×	×

FP DITCH CLEANING BUCKET (QUICK COUPLED)

0.89 (**)	1830	810	○	○	○
		970 (*)	○	○	○
1.48	2130	890	●	●	■
		1080 (*)	●	■	■

(*) with bolt-on cutting edge (**) to be removed for road transport with 3.66 m arm
○ Rated material density up to 2 ton/m³ ● Rated material density up to 1.6 ton/m³

CX300D NLC

HEAVY DUTY BUCKET (PIN ON)

CAPACITY m ³ (ISO7451 HEAPED)	WIDTH mm	WEIGHT kg	ARM 2.65 m	ARM 3.18 m	ARM 3.66 m
0.85	900	1040	○	○	○
1.11	1100	1150	○	○	●
1.24	1200	1240	○	●	●
1.43	1350	1310	●	■	■
1.63	1500	1460	■	■	×

ROCK BUCKET (PIN ON)

0.85	900	1080	○	○	○
1.11	1100	1190	○	○	●
1.24	1200	1280	○	●	■
1.43	1350	1360	●	■	■
1.63	1500	1500	■	■	×

DITCH CLEANING BUCKET (PIN ON)

0.89 (**)	1830	760	○	○	○
		910 (*)	○	○	○
1.48 (**)	2130	830	○	●	●
		1020 (*)	●	●	■

TILTABLE DITCH CLEANING BUCKET (PIN ON)

1.13	1800	1100	○	●	●
1.26	2000	1160	●	●	■
1.39	2200	1250	●	■	■
1.51	2400	1310	■	■	×
1.58	2500	1370	■	■	×

Tilt angle 45° L/R - Connect to Low-Flow Auxiliary Hydraulic Circuit

HD SCOOP BUCKET (QUICK COUPLED)

0.85	900	1030	○	○	●
1.11	1100	1140	●	●	●
1.24	1200	1230	●	■	■
1.43	1350	1310	■	×	×

ROCK SCOOP BUCKET (QUICK COUPLED)

0.85	900	1070	○	○	●
1.11	1100	1180	●	●	■
1.24	1200	1270	●	■	×
1.43	1350	1350	■	×	×

FP DITCH CLEANING BUCKET (QUICK COUPLED)

0.89 (**)	1830	810	○	○	○
		970 (*)	○	○	●
1.48	2130	890	●	■	■
		1080 (*)	■	■	×

■ Rated material density up to 1.2 ton/m³ × Not applicable

www.casece.com
EXPERTS FOR THE REAL WORLD
SINCE 1842

CASE
CONSTRUCTION



Form No. 20194GB - MediaCross Firenze - 01/19

**CNH INDUSTRIAL
DEUTSCHLAND GMBH**
Case Baumaschinen
Benzstr. 1-3 - D-74076 Heilbronn
DEUTSCHLAND

CNH INDUSTRIAL FRANCE, S.A.
16-18 Rue des Rochettes
91150 Morigny-Champigny
FRANCE

CNH INDUSTRIAL - UK
First Floor, Barclay Court 2,
Heavens Walk,
Doncaster - DN4 5HZ
UNITED KINGDOM

CNH INDUSTRIAL - SOUTH AFRICA
Waterfall Business Park
Bekker Street, Howick Close
1685 Midrand - Johannesburg
REPUBLIC OF SOUTH AFRICA

**CNH INDUSTRIAL
MAQUINARIA SPAIN, S.A.**
Avenida Aragón 402
28022 Madrid
ESPAÑA

CNH INDUSTRIAL ITALIA SPA
Strada di Settimo, 323
10099 San Mauro Torinese (TO)
ITALIA

**CASE CUSTOMER CENTRE
PARIS**
RN 330 - Penchard
77122 - Monthyon
FRANCE

CNH INDUSTRIAL - MIDDLE EAST
DAFZA - Dubai Airport Free Zone
West Wing 4 B, Office 642
P.O. Box 54588, Dubai,
UNITED ARAB EMIRATES

NOTE: Standard and optional fittings can vary according to the demands and specific regulations of each country. The illustrations may include optional rather than standard fittings - consult your Case dealer. Furthermore, CNH Industrial reserves the right to modify machine specifications without incurring any obligation relating to such changes.

Conforms to directive 2006/42/EC

CASE
00800-2273-7373

The call is free from a land line.
Check in advance with your Mobile Operator if you will be charged. Toll free number not available from all calling areas.

